



**Zwischenflanschausführung (B)**

**Anflanschausführung (T)**

**Druckstufe: PN 10 / 16**

Flanschanschluss PN 6-10-16, ANSI 150

einteiliges Ringgehäuse aus GGG 40

Epoxidbeschichtet (mind. 80 µm)

Standardanstrich RAL 2002 orange

Dichtung/Manschette: **NBR-70-AG**

Klappenscheibe: Edelstahl (1.4408)

Baulänge gemäß DIN 3202, K1 / EN 558-1, GR20

austauschbare Dichtung

Dichtschließend gemäß EN 12266-1, Leckrate A

Baumusterprüfung 32-0122

### Zulassungen/Zertifikate:

AD 2000, DGU 2014/68/EU, DVGW Gas, Modul C1, H, optional: FDA, ATEX

Nennweite	Zwischenflansch (B)	Anflansch (T)
DN32	AK-994B-32/40	AK-994T-32
DN40		AK-994T-40
DN50	AK-994B-50	AK-994T-50
DN65	AK-994B-65	AK-994T-65
DN80	AK-994B-80	AK-994T-80
DN100	AK-994B-100	AK-994T-100
DN125	AK-994B-125	AK-994T-125
DN150	AK-994B-150	AK-994T-150
DN200	AK-994B-200	AK-994T-200
DN250	AK-994B-250	AK-994T-250
DN300	AK-994B-300	AK-994T-300
DN350	AK-994B-350	AK-994T-350
DN400	AK-994B-400	AK-994T-400
DN450	AK-994B-450	AK-994T-450
DN500	AK-994B-500	AK-994T-500
DN600	AK-994B-600	AK-994T-600



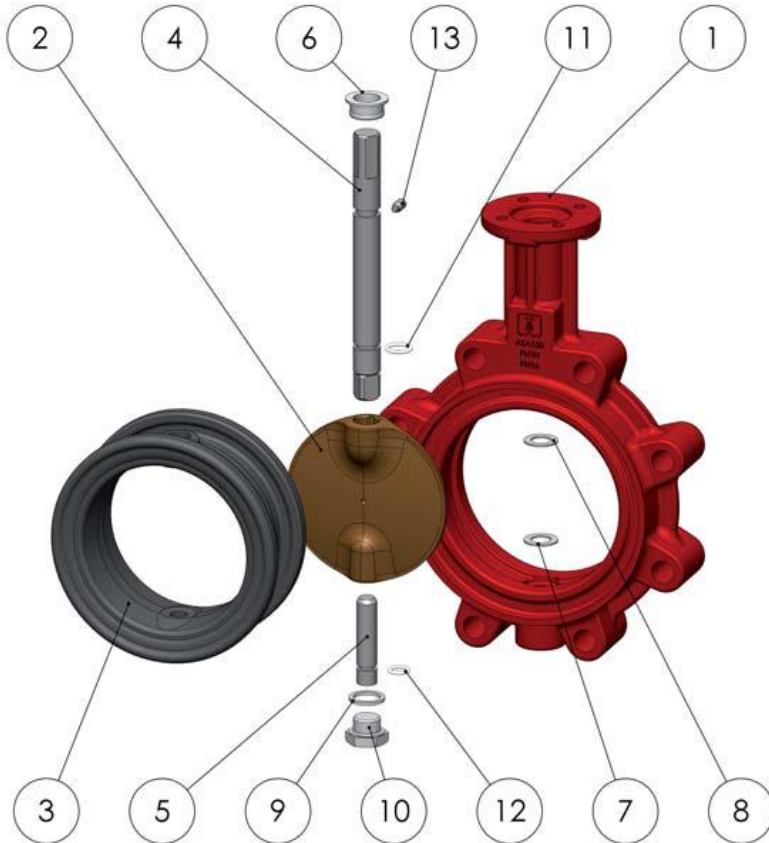

max. Betriebsdruck	
DN 32 ÷ 300	DN 350 ÷ 1600
16 bar	10 bar*

\*16 bar auf Anforderung

Anmerkung:

bei Temperaturen über +120°C ist mit Druckabschlägen von 16 bar auf 14,4 bar, von 10 bar auf 9 bar zu rechnen.



Pos.	MATERIALSPEZIFIKATION	
1	Gehäuse	Sphäroguss 0.7040 (GGG40) mit Epoxidanstrich
		Kohlenstoffstahl 1.0625 (WCB)
		Stahl mit niedrigem Kohlenstoffgehalt 1.1156 (LCC)
		Edelstahl 1.4408 (CF8M)
2	Scheibe	Siehe unten
3	Manschette	siehe unten
4	Welle	Edelstahl 1.4021 (AISI 420)
5	Bolzen	Edelstahl 1.4021 (AISI 420)
6	Wellenlager	Delrin (Polyacetal, bis DN300) oder Messing (ab DN350)
7	Unterlegscheibe Bolzen	Edelstahl 1.4301 (AISI 304, A2)
8	Unterlegscheibe Welle	Edelstahl 1.4301 (AISI 304, A2)
9	Sicherungsstift	Verzinkter Stahl oder Rostfreier Stahl
10	Sicherungsschraube	Edelstahl 1.4401 (AISI 316)
11	O-Ring Welle	NBR, EPDM, Viton auf Anfrage
12	O-Ring Bolzen	NBR, EPDM, Viton auf Anfrage

MANSCHETTE	1	NBR -10°C bis +100°C
	2	EPDM -25°C bis +125°C
	3	NBR Carboxyl -15°C bis +60°C
	4	VITON (FPM) -25°C bis +150°C
	5	Silikon (Dampf, MVQ) -25°C bis +140°C
	6	Silikon (VMQ) -25°C bis +150°C
	7	Epichloridrin -25°C bis +70°C
	8	Hypalon® (CSM) -25°C bis +120°C
	9	NBR-70-AG -10°C bis +60°C
SCHEIBE	0	Messing (2.0402)
	1	Aluminium Bronze (2.0966)
	2	Edelstahl (1.4308)
	3	Sphäroguss GGG40 (0.7040)
	4	Edelstahl (1.4408)*
	5	HASTELLOY
	6	Edelstahl (Uranus B6 / 1.4539)
7	Titanium	

\*HALAR-Anstrich möglich

Zwischenflanschausführung Typ B

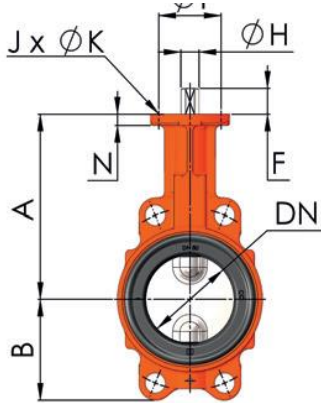

Anflanschausführung Typ T

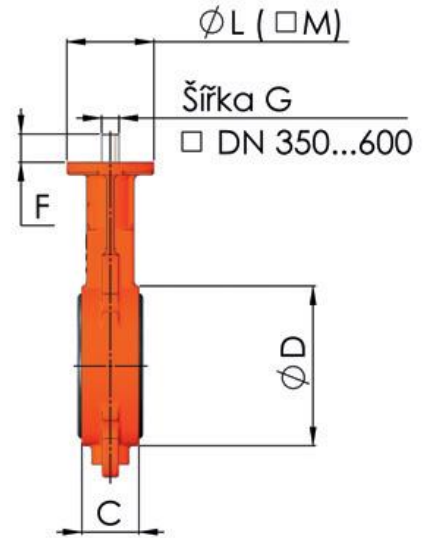
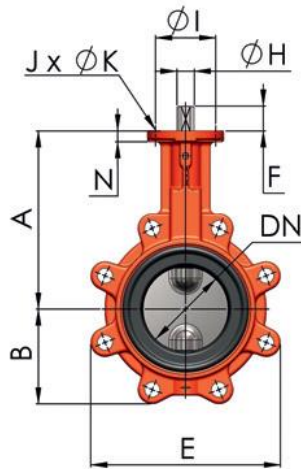

Abmessungen DN 32-600

DN		mm	32	40	50	65	80	100	125	150	200	250	300	350	400	450	500	600	
		inch	1¼"	1½"	2"	2½"	3"	4"	5"	6"	8"	10"	12"	14"	16"	18"	20"	24"	
Version	B	A	136	136	146	154,0	163	173,0	193,0	205	234	270	310	325	365	375	485	565	
	T	A	136	136	146	154,0	163	173,0	193,0	205	234	270	310	325	365	375	485	565	
Klappenabmessung		B	54	54	64	72	89	105	119	130	166	202	237	271	314	330	368	464	
		C	33	33	43	46	46	52	56	56	60	68	78	78	102	114	127	154	
		D	78	78	96	113	128	150	184	212	268	320	378	435	488	544	590	695	
		E	110	110	115	129	174	204	234	255	319	396	465	509	590	610	682	810	
Wellenabmessung		F	25	25	25	25	25	25	25	25	25	30	30	36	36	80	80	80	
		G	14						17			22	22	27	27	10	12	14	
		H	-	-	-	-	-	-	-	-	-	-	-	-	-	Ø38	Ø42	Ø50	
ISO TOP Flansch		I	50						70			102	102	125	140	140	140	165	
		J	4																
		K	7						9			11	11	14	18	18	18	23	
Flanschabmessung		L	-	-	70			-	-	-	-	-	-	-	-	-	175	175	210
		M	70	70	-	-	-	-	70	70	70	105	105	130	140	-	-	-	
		N	8	8	8	8	8	8	12	12	14	17	17	17	21	22	25	25	
Gewicht	Version		1,9	1,9	2,7	3,2	3,7	4,7	6,7	8,4	13,3	22	29,3	46,4	69,8	83	112	216	
	B		1,9	1,9	2,7	3,2	3,7	4,7	6,7	8,4	13,3	22	29,3	46,4	69,8	83	112	216	
	T		2,3	2,3	3	3,7	4,8	6,1	9,2	10,2	15,3	28,4	41,2	62	96,3	130	149	288	

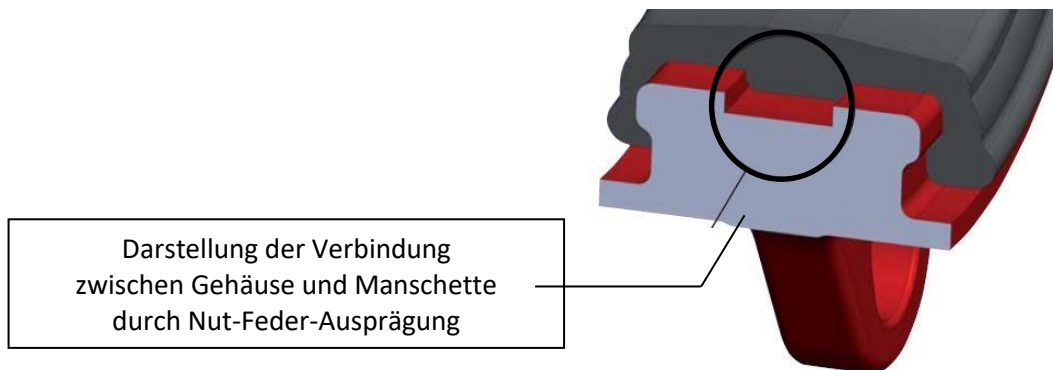

### Anschluss zwischen Flanschen

Vers.		32/40	50	65	80	100	125	150	200	250	300	350	400	450	500	600
B	PN 6											•	•	•	•	•
	PN10															
	PN16													•		
	Cl.150											•	•	•	•	•
T	PN 6	•	•	•	•	•	•	•	•	•	•	•	•	-	-	-
	PN10													•	•	•
	PN16								•	•	•	•	•	•	•	•
	Cl.150	•	•	•	•	•	•	•	•	•	•	•	•	•	•	•

	standard
•	auf Anforderung

### Betätigungsart: Handhebel

DN	32-100	125	150-200	250	300
A	270	270	362	450	750
B	75	75	75	135	135
Gewicht	1,24	1,24	1,4	2,2	3,1

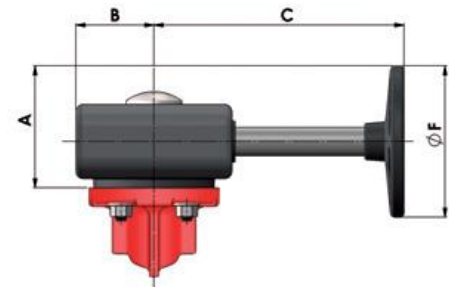
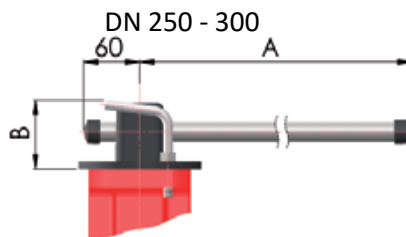
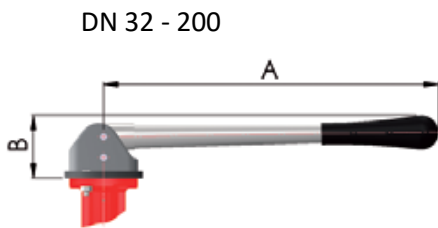

### Betätigungsart: Getriebe mit Handrad

DN	32 - 125	150 - 300	350	400	450 - 500	600
A	89	155	225	275		350
B	51	66	99		126	158
C	152	252	245	285	337	382
D	44	59	96		118	145
E	101	177	265	315	348	454
F	125	250	350	450		600
Gewicht	1,6	3,7	6,6		14,5	27,2
Rad	SE07	SE10	M14		M15	M16

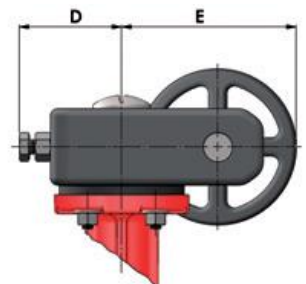

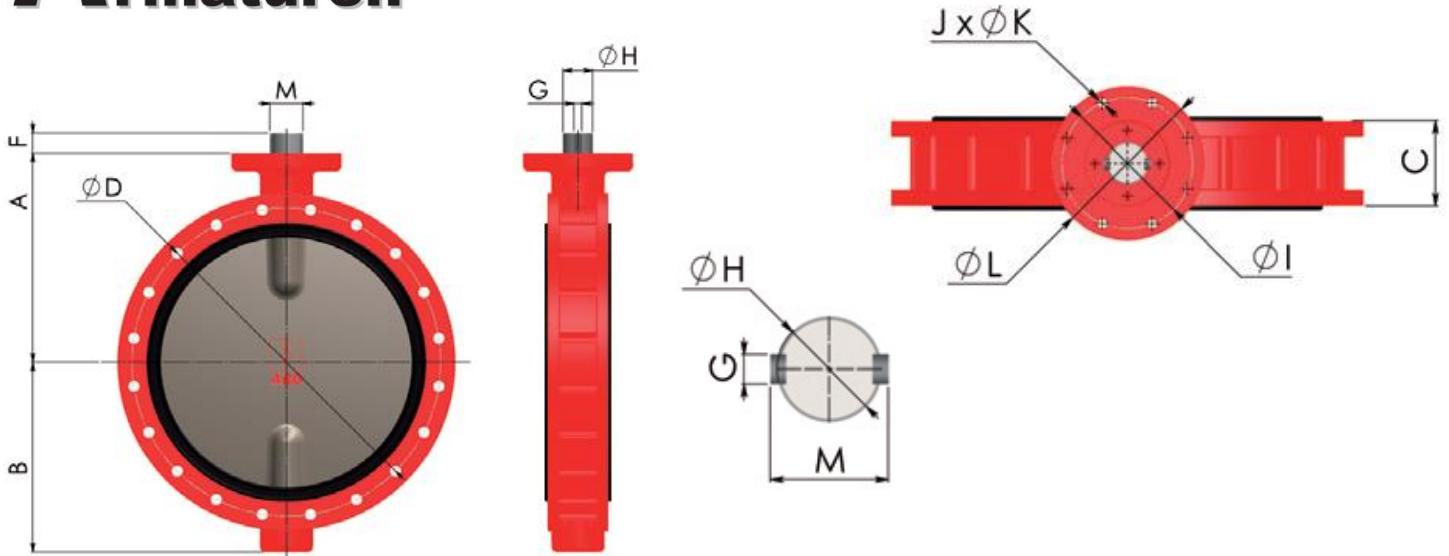

### Abmessungen DN 700-1600

### Drehmomente bei Betriebsdruck (Nm)

DN	mm	700	800	900	1000	1200	1400	1600
Version - Doppelflansch	inch	28"	32"	36"	40"	48"	56"	64"
Klappenabmessungen	A	629	666	720	800	940	1009	1150
	B	537	601	656	720	844	1014	1045
	C	165	190	203	216	254	279	318
	D	840	950	1050	1160	1380	1590	1820
Wellenabmessungen	F	95	95	130	130	150	150	200
	G	16	16	20	22	28	32	40
	H	55	55	75	85	105	120	160
	M	63	63	84	95	117	134	178
ISO Kopfflansch - abmessungen	I	254	254	254	254	298	356	356
	J	8	8	8	8	8	8	8
	K	18	18	18	18	22	33	33
	L	300	300	300	300	350	415	415
ISO Kopfflansch		F25	F25	F25	F25	F30	F40	F40
Gewicht		350	580	700	850	1080	1922	2350

Weitere Optionen auf Anfrage