



Wafer Type (B)

Lug Type (T)

Nominal Pressure: PN 10 / 16

Flange connection: PN 6-10-16, ANSI 150

One piece body in GGG 40

Epoxy Coated (min. 80 µm)

Standard coating color: RAL 2002 orange

Seat: **NBR-70-AG**

Disc: Stainless steel (1.4408)

Face to face acc. to DIN 3202, K1 / EN 558-1, R20

Exchangeable Seats

Tightness check acc. to EN 12266-1, Leakage rate A

Type examination 32-0122

Tests/Certificates:

AD 2000, DGU 2014/68/EU, DVGW gas, Modul C1, H, optional: FDA, ATEX

Nominal Diameter	Wafer type (B)	Lug type (T)
DN32	AK-994B-32/40	AK-994T-32
DN40		AK-994T-40
DN50	AK-994B-50	AK-994T-50
DN65	AK-994B-65	AK-994T-65
DN80	AK-994B-80	AK-994T-80
DN100	AK-994B-100	AK-994T-100
DN125	AK-994B-125	AK-994T-125
DN150	AK-994B-150	AK-994T-150
DN200	AK-994B-200	AK-994T-200
DN250	AK-994B-250	AK-994T-250
DN300	AK-994B-300	AK-994T-300
DN350	AK-994B-350	AK-994T-350
DN400	AK-994B-400	AK-994T-400
DN450	AK-994B-450	AK-994T-450
DN500	AK-994B-500	AK-994T-500
DN600	AK-994B-600	AK-994T-600



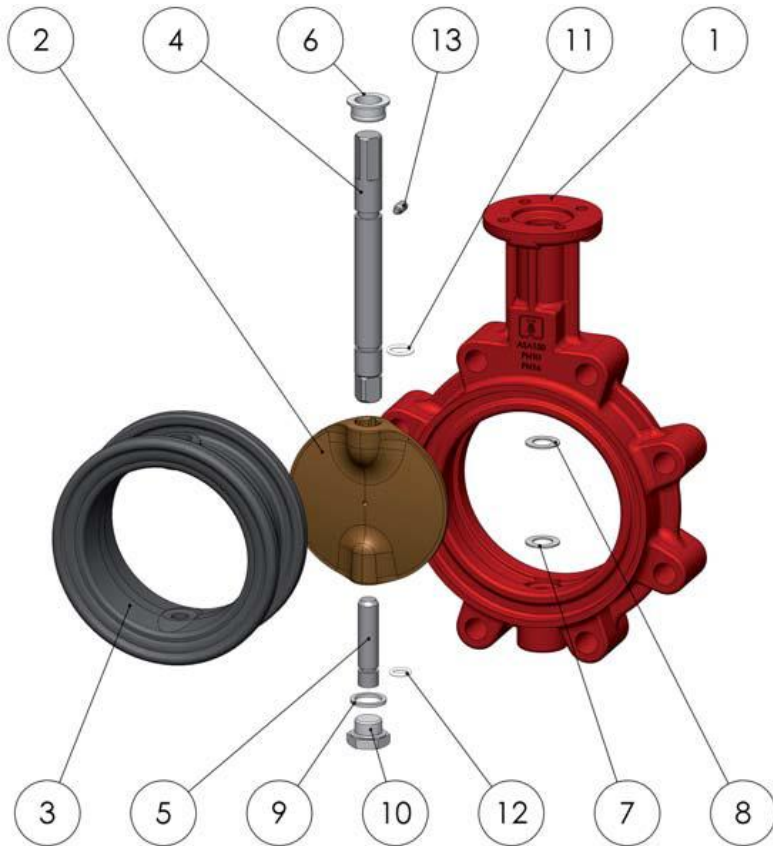

max. operating pressure	
DN 32 ÷ 300	DN 350 ÷ 1600
16 bar	10 bar*

*16 bar upon request

Note:

at temperatures above +125°C sudden pressure reductions can occur: 16 bar to 14,4 bar and 10 bar to 9 bar.



No.	Material of Construction	
1	Body	Ductile iron 0.7040 (GGG40) epoxy coated
		Carbon steel 1.0625 (WCB)
		Low temperature carbon steel 1.1156 (LCC)
		Stainless steel 1.4408 (CF8M)
2	Disc	see below
3	Seat	see below
4	Shaft	Stainless steel 1.4021 (AISI 420)
5	Pivot	Stainless steel 1.4021 (AISI 420)
6	Bushing	Delrin (up to DN300) or brass (from DN350)
7	Distance Ring	Stainless steel 1.4301 (AISI 304, A2)
8	Distance Ring	Stainless steel 1.4301 (AISI 304, A2)
9	Seal	Verzinkter Stahl oder Rostfreier Stahl
10	Plug Screw	Edelstahl 1.4401 (AISI 316)
11	Shaft O-Ring	NBR, EPDM, Viton is an option
12	Pivot O-Ring	NBR, EPDM, Viton is an option

Seat	1	NBR -10°C to +100°C
	2	EPDM -25°C to +125°C
	3	Carboxylic NBR -10°C bis +100°C
	4	Viton (FKM) -15°C bis +150°C
	5	Steam silicone (MVQ) -30°C bis +140°C
	6	Silicone (MVQ) -30°C bis +150°C
	7	Epichlorohydrin -30°C bis +70°C
	8	Hypalon© (CSM) -25°C bis +120°C
	9	NBR-70-AG -10°C bis +60°C
Disc	0	Brass (2.0402)
	1	Aluminium bronze (2.0975)
	2	Stainless steel (1.4308)
	3	Ductile iron GGG40 (0.7040)
	4	Stainless steel (1.4408)*
	5	Hastelloy
	6	Stainless steel (1.4539)
7	Titanium	

*HALAR-coating is an option

Wafer type B

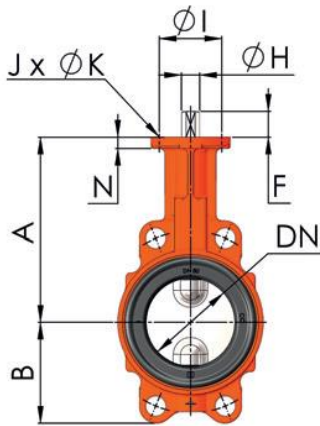

Lug type T

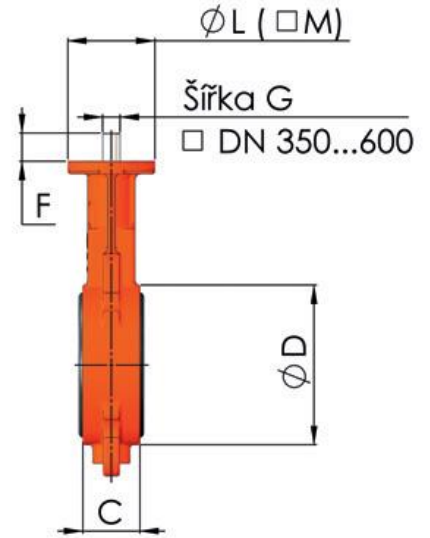
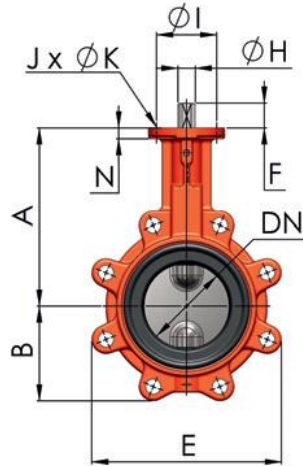

Dimensions DN 32-600

DN	mm	32	40	50	65	80	100	125	150	200	250	300	350	400	450	500	600	
	inch	1¼"	1½"	2"	2½"	3"	4"	5"	6"	8"	10"	12"	14"	16"	18"	20"	24"	
Body type	B	A	136	136	146	154,0	163	173,0	193,0	205	234	270	310	325	365	375	485	565
	T	A	136	136	146	154,0	163	173,0	193,0	205	234	270	310	325	365	375	485	565
Valve dimensions	B	54	54	64	72	89	105	119	130	166	202	237	271	314	330	368	464	
	C	33	33	43	46	46	52	56	56	60	68	78	78	102	114	127	154	
	D	78	78	96	113	128	150	184	212	268	320	378	435	488	544	590	695	
	E	110	110	115	129	174	204	234	255	319	396	465	509	590	610	682	810	
Endshaft dimensions	F	25	25	25	25	25	25	25	25	25	30	30	36	36	80	80	80	
	G	14						17			22	22	27	27	10	12	14	
	H	-	-	-	-	-	-	-	-	-	-	-	-	-	Ø38	Ø42	Ø50	
ISO flange	I	50						70			102	102	125	140	140	140	165	
	J	4																
	K	7						9			11	11	14	18	18	18	23	
Flange dimensions	L	-	-	70			-	-	-	-	-	-	-	-	175	175	210	
	M	70	70	-	-	-	-	70	70	70	105	105	130	140	-	-	-	
	N	8	8	8	8	8	8	12	12	14	17	17	17	21	22	25	25	
Weight	Type B	1,9	1,9	2,7	3,2	3,7	4,7	6,7	8,4	13,3	22	29,3	46,4	69,8	83	112	216	
	Type T	2,3	2,3	3	3,7	4,8	6,1	9,2	10,2	15,3	28,4	41,2	62	96,3	130	149	288	

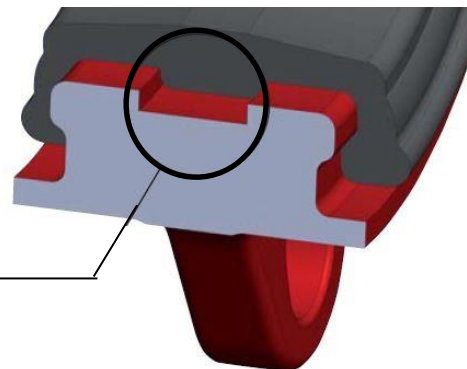

Example of groove and tongue liner anchoring whereby the forming prevents liner from movement.

Installation between flanges

Vers.		32/40	50	65	80	100	125	150	200	250	300	350	400	450	500	600
B	PN 6											•	•	•	•	•
	PN10															
	PN16													•		
	Cl.150											•	•	•	•	•
T	PN 6	•	•	•	•	•	•	•	•	•	•	•	•	-	-	-
	PN10													•	•	•
	PN16								•	•	•	•	•	•	•	•
	Cl.150	•	•	•	•	•	•	•	•	•	•	•	•	•	•	•
	standard															
•	on request															

Manual actuation: Handlever

DN	32-100	125	150-200	250	300
A	270	270	362	450	750
B	75	75	75	135	135
Weight	1,24	1,24	1,4	2,2	3,1

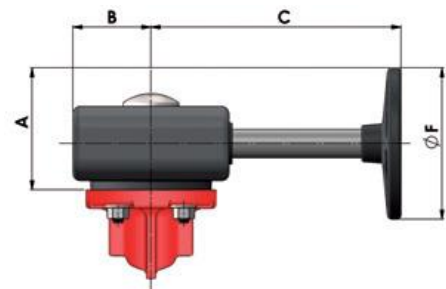
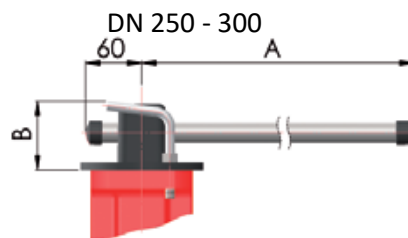
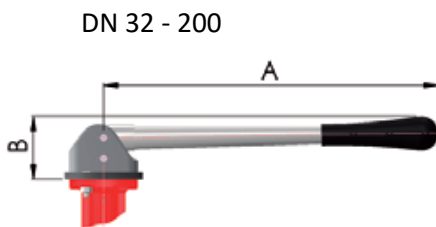

Manual gearbox with handwheel

DN	32 - 125	150 - 300	350	400	450 - 500	600
A	89	155	225	275		350
B	51	66	99		126	158
C	152	252	245	285	337	382
D	44	59	96		118	145
E	101	177	265	315	348	454
F	125	250	350	450		600
Weight	1,6	3,7	6,6		14,5	27,2
Wheel	SE07	SE10	M14		M15	M16

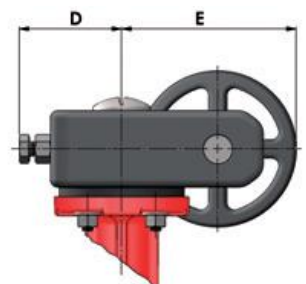

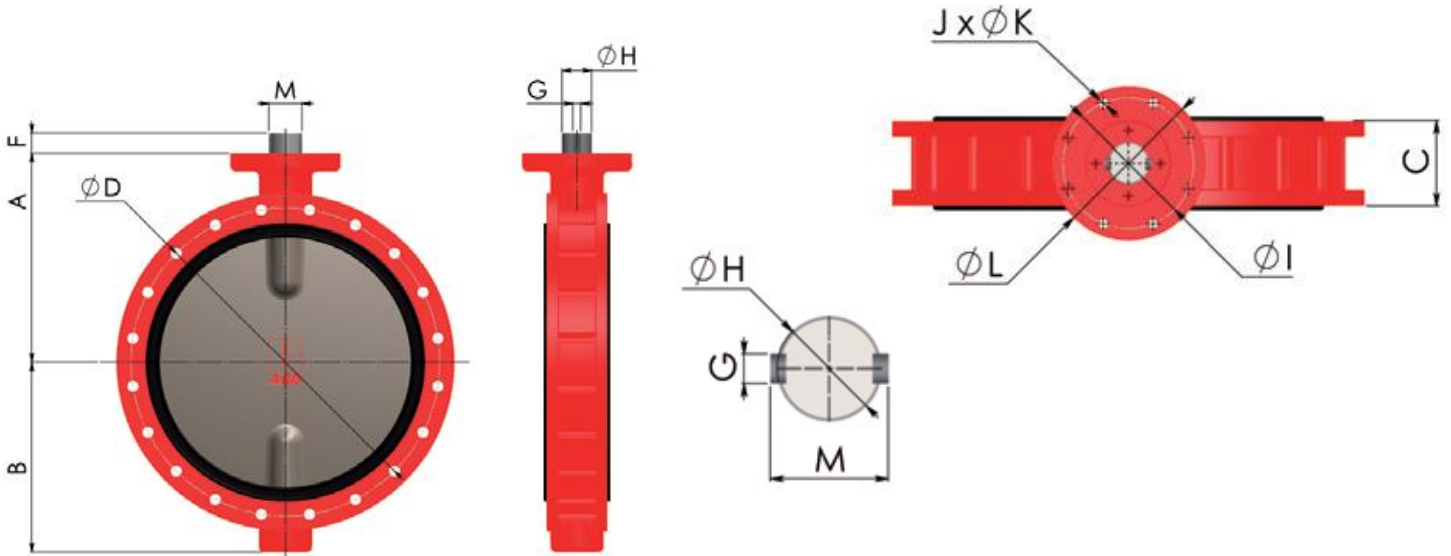

Dimensions DN 700-1600

DN	mm	700	800	900	1000	1200	1400	1600
Version – double flange	inch	28"	32"	36"	40"	48"	56"	64"
Valve dimensions	A	629	666	720	800	940	1009	1150
	B	537	601	656	720	844	1014	1045
	C	165	190	203	216	254	279	318
	D	840	950	1050	1160	1380	1590	1820
Endshaft dimensions	F	95	95	130	130	150	150	200
	G	16	16	20	22	28	32	40
	H	55	55	75	85	105	120	160
	M	63	63	84	95	117	134	178
ISO flange	I	254	254	254	254	298	356	356
	J	8	8	8	8	8	8	8
	K	18	18	18	18	22	33	33
	L	300	300	300	300	350	415	415
ISO flange		F25	F25	F25	F25	F30	F40	F40
Weight		350	580	700	850	1080	1922	2350

More options upon request.