



Nominal Pressure: PN 6 / 10 / 16 / 25 / 40 / 64 / ANSI150

Mounted directly between flanges

Body: Steel, zinc plated (1.0619)

Disc: Steel, zinc plated (1.0619)

ZRK = without spring return

ZRKF = with spring return

Spring: Stainless Steel (1.4571)

Seal material: see table

Nominal Diameter	Article number	
	without spring	with spring
DN32	ZRK-ST-ST-X-32	ZRKF-ST-ST-X-32
DN40	ZRK-ST-ST-X-40	ZRKF-ST-ST-X-40
DN50	ZRK-ST-ST-X-50	ZRKF-ST-ST-X-50
DN65	ZRK-ST-ST-X-65	ZRKF-ST-ST-X-65
DN80	ZRK-ST-ST-X-80	ZRKF-ST-ST-X-80
DN100	ZRK-ST-ST-X-100	ZRKF-ST-ST-X-100
DN125	ZRK-ST-ST-X-125	ZRKF-ST-ST-X-125
DN150	ZRK-ST-ST-X-150	ZRKF-ST-ST-X-150
DN200	ZRK-ST-ST-X-200	ZRKF-ST-ST-X-200
DN250	ZRK-ST-ST-X-250	ZRKF-ST-ST-X-250
DN300	ZRK-ST-ST-X-300	ZRKF-ST-ST-X-300

Short form	Seal material	Temperature range
N	NBR	-10° bis +90°C
F	FPM (Viton)	-10° bis +150°C
E	EPDM	-10° bis +120°C
T	PTFE	-10° bis +200°C
M	metal	-10° bis +300°C

Other versions upon request

DN 32 - 40

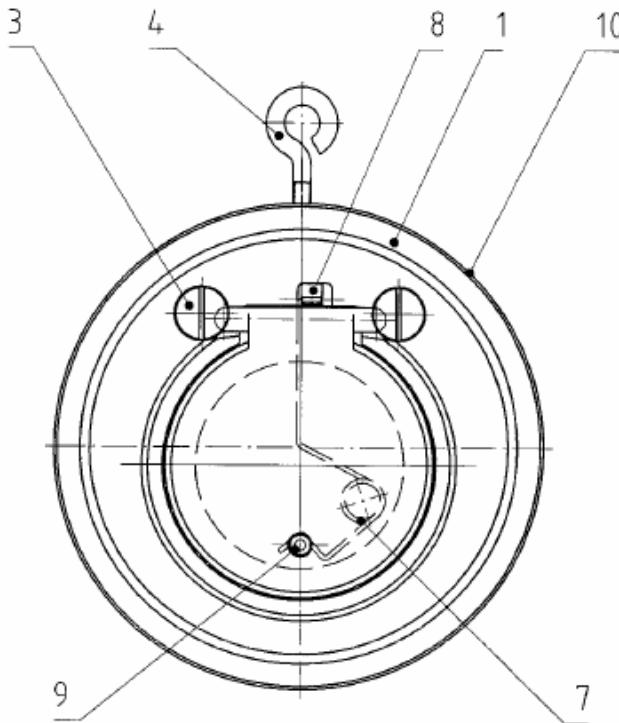

DN 50 - 125

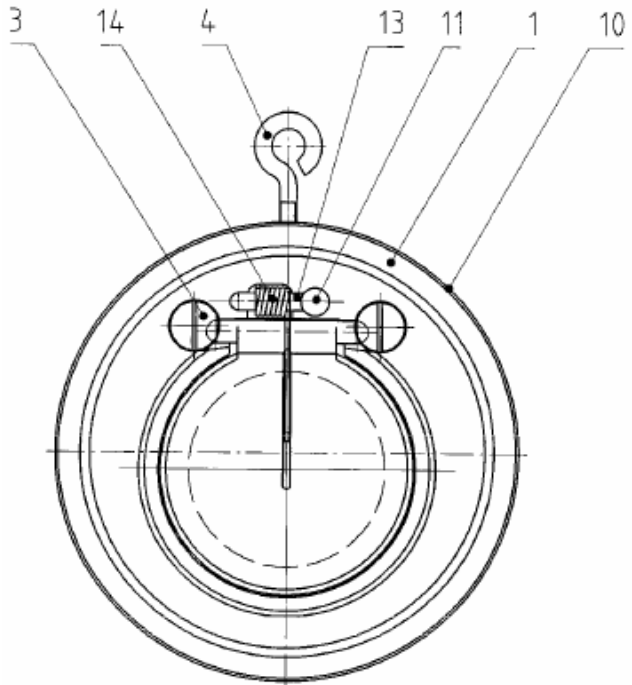

ab DN 150
from DN 150

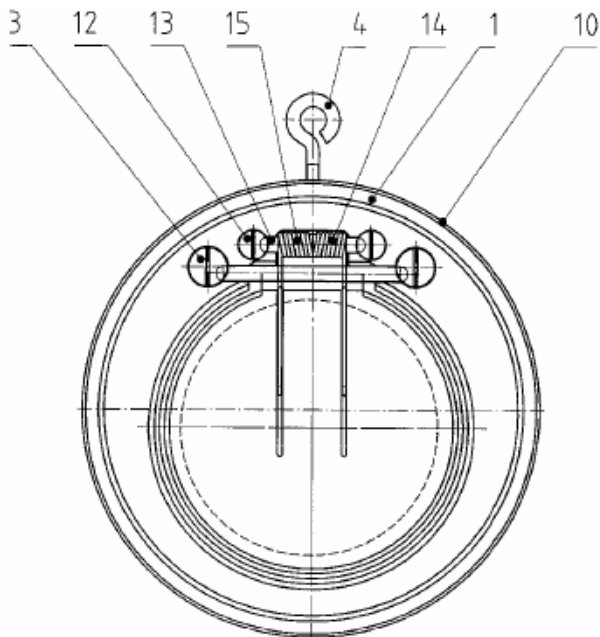

Maßzeichnung
Dimension drawing

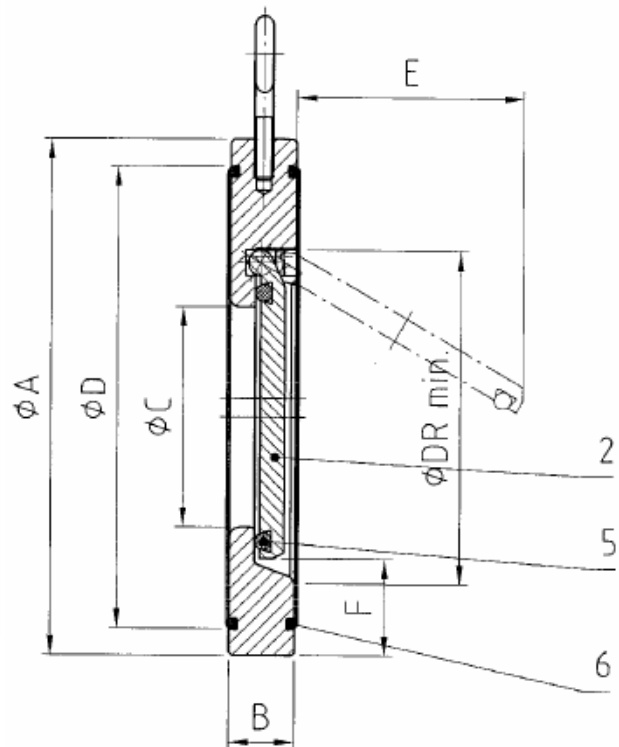

∅ DN (mm)	A	B	C	D	E	DR	kg
PN16							
32	85	15	18	59	22	37	0,5
40	95	16	22	72	25	43	0,8
50	109	14	32	86	37	54	1,0
65	129	14	40	109	50	70	1,4
80	144	14	54	119	61	82	1,8
100	164	18	70	146	77	106	2,9
125	195	18	92	173	98	131	3,9
150	220	20	112	197	120	159	4,5
200	275	22	154	255	160	207	7,5
250	331	26	192	312	190	260	13,0
300	386	32	227	363	220	309	23,0

No.	Part Name	Material	No.	Part Name	Material
1	Body	Steel, zinc plated (1.0619)	9	Retaining bolt	Stainless steel 1.4305
2	Disc	Steel, zinc plated (1.0619)	10	Type plate	1.1181
3	Screw	Stainless steel 1.4401	11	Retaining bolt for pin	Stainless steel 1.4401
4	Ring bolt	Galvanised steel	12	Screw	Stainless steel 1.4401
5	O-Ring	A276 410	13	Pin for screw	Stainless steel 1.4408
6	O-Ring	A193 B7	14	Right spring	Stainless steel
7	Spring	Stainless steel 1.4571	15	Left spring	Stainless steel
8	Trunnion	Stainless steel			

∅ DN (mm)	Kv-value m ³ /h	Opening pressure in mbar at flow direction			
		↔	↔	↑	↑
		without spring	with spring	without spring	with spring
32	16,2	~ 2	~ 15	~ 10	~ 25
40	22,2	~ 2	~ 15	~ 10	~ 25
50	54	~ 2	~ 15	~ 10	~ 25
65	75	~ 2	~ 15	~ 10	~ 25
80	112	~ 2	~ 15	~ 10	~ 25
100	172	~ 2	~ 15	~ 10	~ 25
125	342	~ 2	~ 15	~ 10	~ 25
150	490	~ 2	~ 15	~ 10	~ 25
200	1128	~ 4	~ 17	~ 14	~ 25
250	1500	~ 4	~ 17	~ 14	~ 25
300	2290	~ 4	~ 17	~ 14	~ 25